



# 2 DOORS STAINLESS STEEL REFRIGERATED SANDWICH PREP TABLE

Model # P48S

## FEATURES

- Top accommodates (12) 1/6 size, 6" deep food pans
- Industry-best 3/4 cutting board is built-in for convenient prep space and removable for cleaning
- Digital control with auto defrost
- Stainless steel exterior and interior; foamed-in-place polyurethane insulation
- Includes 5 divider bars; 1/2 hp; 2.4 Amps
- 5 year compressor 3 year parts 1 year labor warranty





PRODUCT SPECIFICATIONS

# 2 DOORS STAINLESS STEEL REFRIGERATED SANDWICHPREP TABLE

Model # P48S

PLAN VIEW

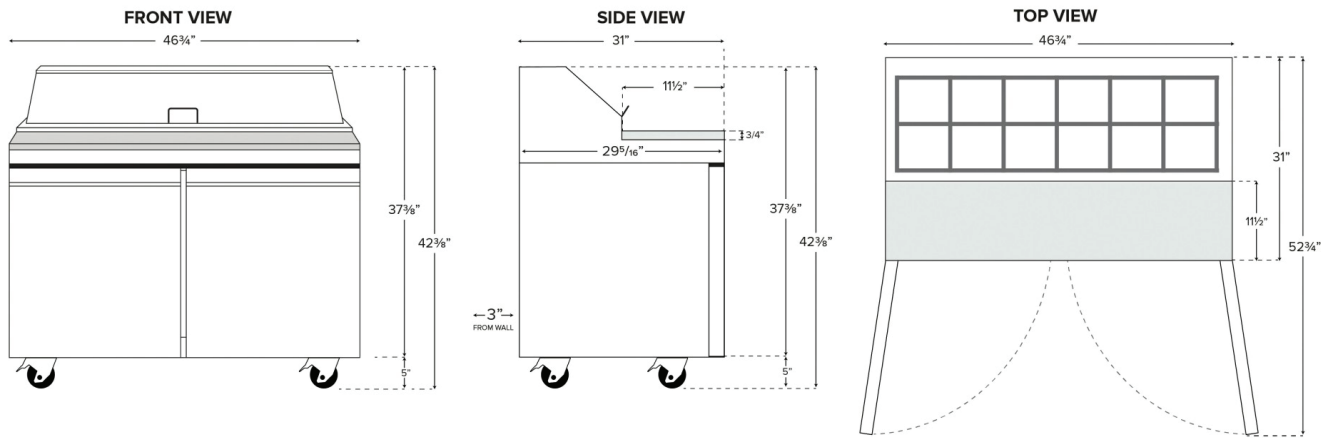

TECHNICAL DATA

Width	46 3/4 Inches	Casters	With Casters
Depth	31 Inches	Compressor Style	Side / Rear Breathing
Height	42 3/8 Inches	Door Style	Swing
Interior Width	42 7/8 Inches	Door Type	Solid
Cutting Board Depth	11 1/2 Inches	Hinge Location	Left/Right
Interior Depth	23 3/4 Inches	Horsepower	1/2 HP
Interior Height	23 1/2 Inches	Number of Doors	2 Doors
Work Surface Height	35 1/4 Inches	Plug Type	NEMA 5-15P
Amps	2.4 Amps	Refrigerant Type	R-290
Hertz	60 Hertz	Refrigeration Type	Air Cooled
Phase	1 Phase	Style	Counter Height
Voltage	115 Volts	Temperature Range	33 - 40 Degrees F
1/6 Size Pan Capacity	12 Pans	Top Type	Standard Top
Access Type	Doors	Type	Prep Refrigeration
BTU (LBP)	1285		
Capacity	12 cu. ft.		

