



DRAWER REFRIGERATED CHEF BASE

Model # PCB48

FEATURES

- 880 lb. weight capacity; 1 3/4" stainless steel top with marine edge
- Each drawer holds 2 full size food pans, 4" deep
- Stainless steel exterior for durability
- Heavy duty refrigeration system to maintain temp and
- Heavy duty Stainless construction
- Heavy duty draw slides
- Heavy duty casters
- Digital temperature display
- 115V; environmentally friendly R290 refrigerant; 1.6Amps





PRODUCT SPECIFICATIONS

DRAWER REFRIGERATED CHEF BASE

Model # PCB48

PLAN VIEW

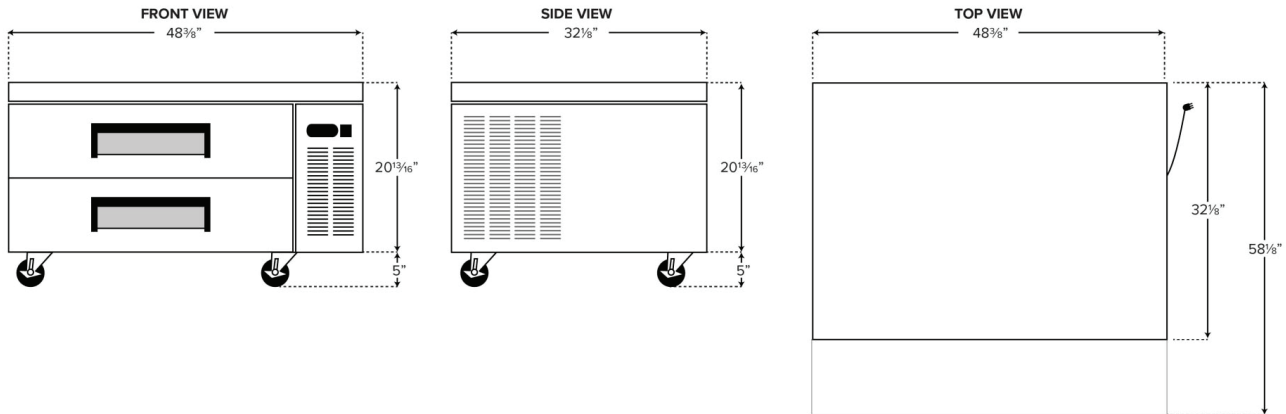

TECHNICAL DATA

Width	48 3/8 Inches	Compressor Location	Side Mounted
Depth	32 1/8 Inches	Drawer Capacity	132 lb.
Height	25 13/16 Inches	Features	Automatic Electric Defrost Digital Temperature Controller
Power Cord Length	84 Inches	Insulation Material	Polyurethane Foam
Interior Width	36 5/8 Inches	Material	Stainless Steel
Packaging Width	50.9375	Maximum Ambient Temperature	90 Degrees F
Interior Depth	27 9/16 Inches	Net Weight	203 lb.
Packaging Depth	34.875	Number of Drawers	2 Drawers
Interior Height	16 9/16 Inches	Plug Type	NEMA 5-15P
Packaging Height	28.5	Refrigerant Type	R-290
Amps	1.6 Amps	Temperature Range	33 - 40 Degrees F
Hertz	60 Hertz	Top Capacity	880 lb.
Phase	1 Phase	Top Material	Stainless Steel
Voltage	115 Volts	Top Style	Marine Edge
Access Type	Drawers	Top Thickness	1.75
Base Style	Refrigerator		
BTU (LBP)	786		
Capacity	9.6 cu. ft.		