



AIR COOLED MODULAR FULL CUBE ICE MACHINE WITH BIN - 350 LB.

Model # SK329

Capable of producing up to 350-420 lb. of full cube ice per day, you'll always have plenty of ice to serve on demand. At only 22" in width, this narrow unit is great for tight bars, kitchens and coffee shops. An included ice bin holds up to an impressive 350 lb. of ice, making it ideal for busy establishments that can not afford long periods of downtime while ice is being made.

FEATURES:

- Includes sanitary ice scoop with interior hook for convenient scoop storage.
- Easy access flip-up door stays open when it is pulled all the way back, so it does not need held while scooping.
- Four adjustable legs accommodate uneven floors or to raise or lower its working height.

STORAGE CAPACITY

- Stores up to 350-420 lb of ice so it is ready to be served or bagged for stock.

BIN EXTERIOR

- Type 304 stainless steel provides better corrosion resistance and is easy to clean.

BIN INTERIOR

- Polyethylene line for increased sanitation and scratch resistance.
- Colored blue for better ice visibility.





PRODUCT SPECIFICATIONS

AIR COOLED MODULAR FULL CUBE ICE MACHINE WITH BIN - 350 LB.

Model # SK329

PLAN VIEW

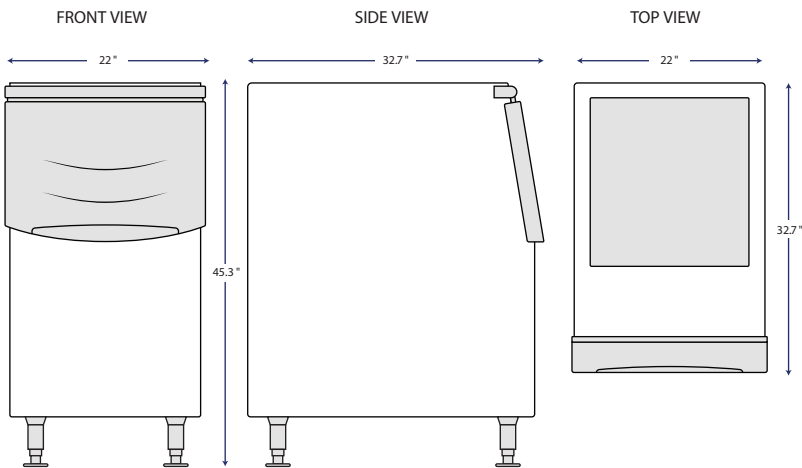

Dimensions

Unit Dimensions	22"W x 32.7"D x 45.3"H
Net Weight	78 lb.
Gross Weight	89 lb.
Packaging Dimensions	25.4"W x 35.1"D x 41.6"H

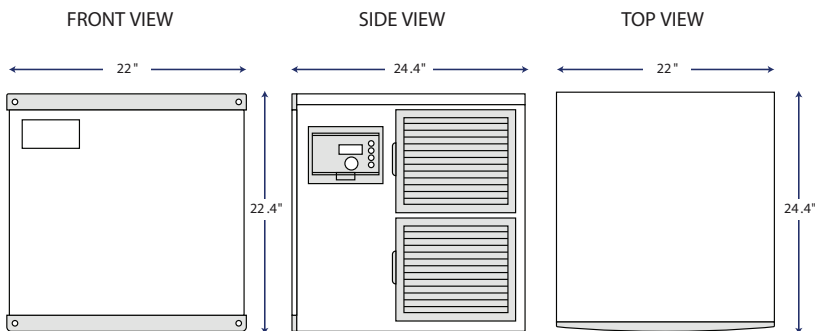

Installation Requirements

Ambient Temperature Range	40° to 90°F
Water Temperature Range	40° to 90°F
Water Pressure Range	18.75 psi min; 80 psi max
Potable Water Usage	15 gal/100 lbs. ice

Dimensions

Unit Dimensions	22"W x 24.4"D x 22.4"H
Net Weight	115 lb.
Gross Weight	124 lb.
Packaging Dimensions	25.8 "W x 29.6"D x 24.5"H

Electrical

Voltage	115
Amps	9.4
Hz	60
Phase	1
Plug Type	NEMA 5-15P
BTU/hr	3207
Power kWh/100 lbs. ice	5.2
Refrigeration Type	R290

Specifications subject to change without notice