

# PRECISION HD SD SERIES HIGH BTU SAUTE RANGE

Model RGR48

## Features

- 37,000 BTU per burner with proper gas pressure
- Heavy cast iron top grates and removable burners
- Full size oven porcelain coated with 2 oven racks
- Easily movable on locking casters
- Fully welded frame
- Stainless front, riser and shelf
- High output BTU's
- Six open top anti clog burners
- Bakers depth full size oven
- 2 oven racks with 6 positions



(401)-639-3271

[www.northamericanrefrigeration.com](http://www.northamericanrefrigeration.com)

© 2016 North American Restaurant Equipment





Product Specifications  
Model RGR48

# PRECISION HD SD SERIES HIGH BTU SAUTE RANGE

Width	48"
Depth	32"
Height	56 3/4"
Ovens	2
Burners	8

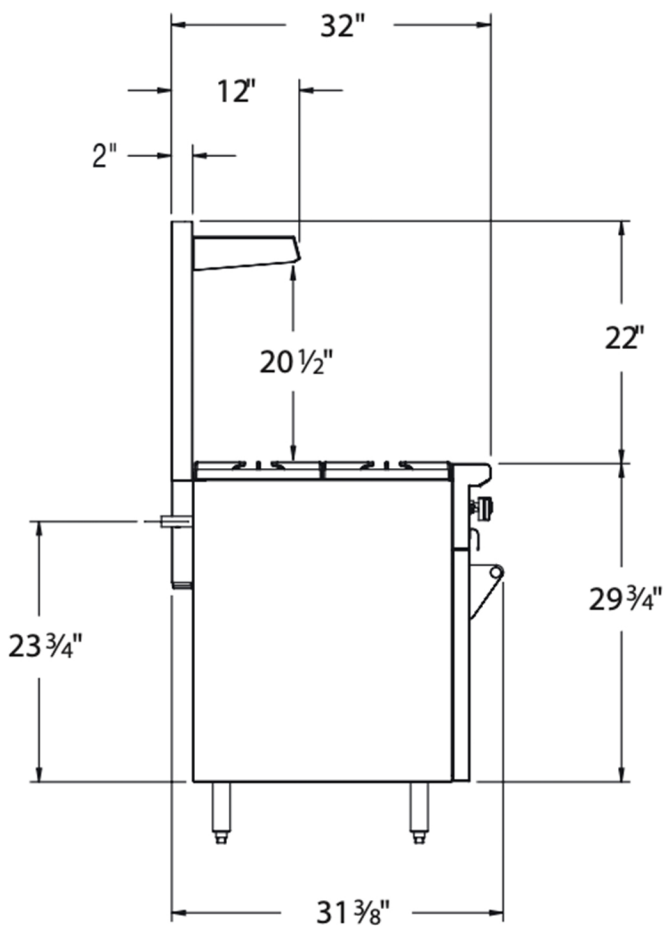

(401)-639-3271

[www.northamericanrefrigeration.com](http://www.northamericanrefrigeration.com)

© 2016 North American Restaurant Equipment

