

90" KEG REFRIGERATOR

Model PUDD90

Features

- Heavy-Duty Construction with Stainless Steel Top Surface
- Black Coated Steel Exterior
- (3) Self-Closing, Locking Doors
- Includes (4) "D" Couplers Per Tap
- Foamed-in-Place Insulation
- (6) Epoxy-Coated Steel Shelves
- (2) Double Tap Towers
- Environmentally-Safe R290 Refrigerant
- LED Interior Lights
- Digital Controls
with Auto Defrost Feature
- Built-in Drip Tray
with Front-Facing Drain



(401)-639-3271

www.northamericanrefrigeration.com

© 2016 North American Restaurant Equipment





Product Specifications
Model PUDD90

90" KEG REFRIGERATOR

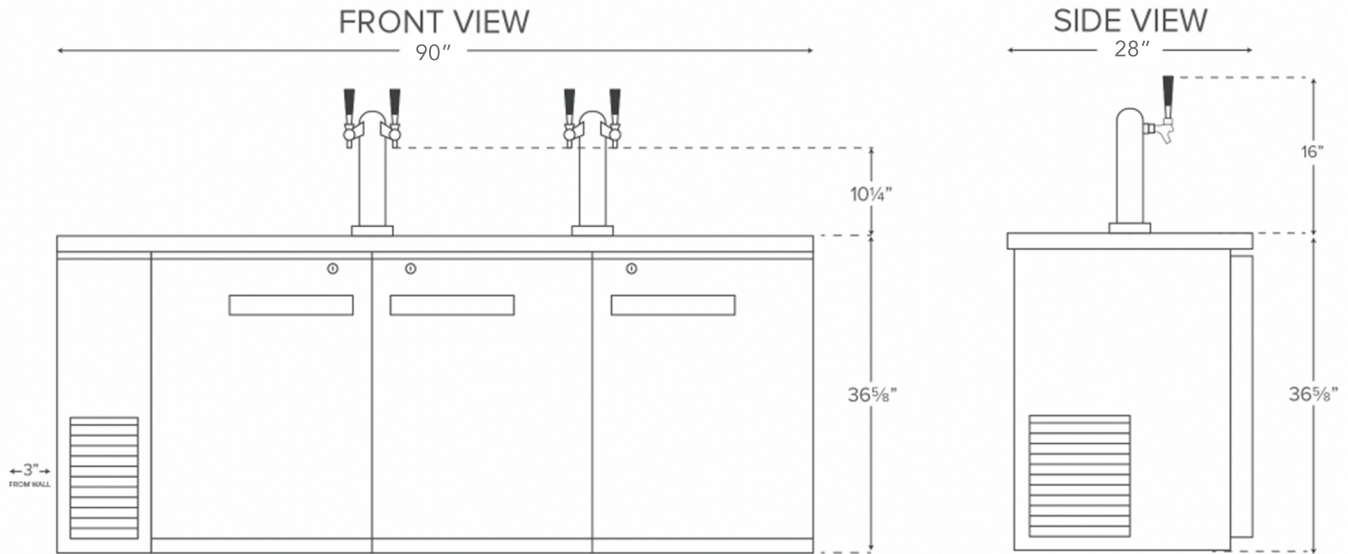

TOP VIEW

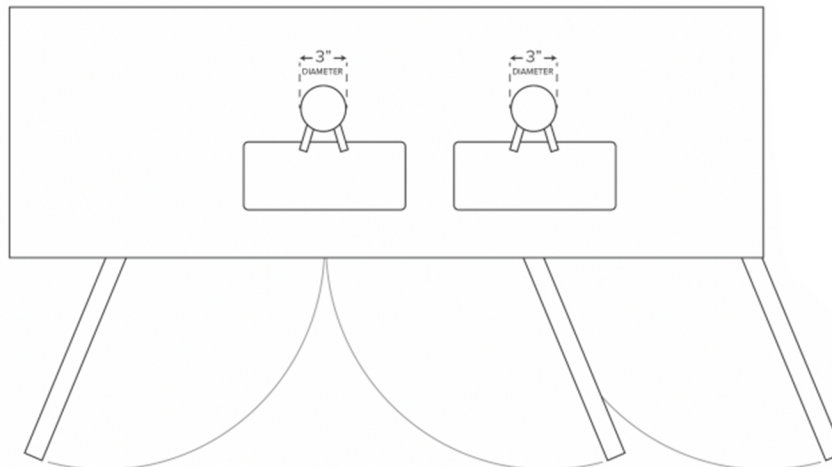

NEMA 5-15P

(401)-639-3271

www.northamericanrefrigeration.com

© 2016 North American Restaurant Equipment



Intertek



Intertek