

# 24" DOUBLE TAP KEGERATOR BEER DISPENSER

Model #PUDD24

## Features

- Durable and attractive black coated steel exterior
- 2 tap tower with 10 1/4" faucet height
- Digital controls for easy-to-read temperature display
- Includes (2) "D" system keg couplers and keg mat
- 115V; 1/4 hp compressor; R290 refrigerant

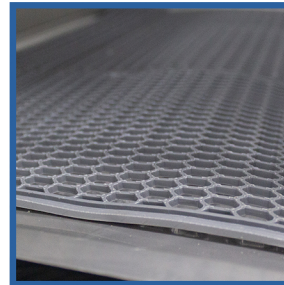
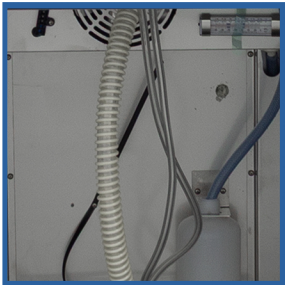

(401)-639-3271

[www.northamericanrefrigeration.com](http://www.northamericanrefrigeration.com)

© 2016 North American Restaurant Equipment





Product Specifications  
Model #PUDD24

# 24" DOUBLE TAP KEGERATOR BEER DISPENSER

## PLAN VIEW

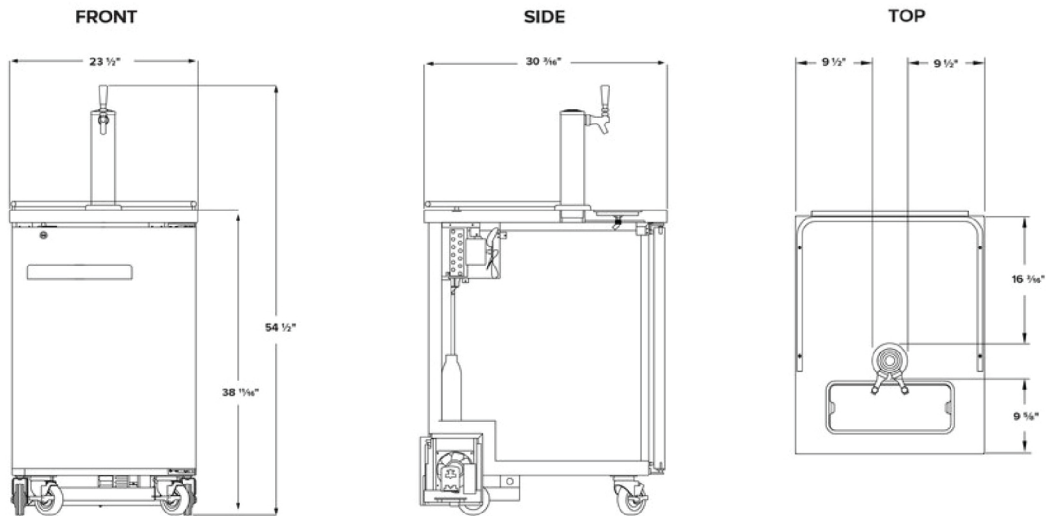

## TECHNICAL DATA

Width	23 1/2 Inches	Compressor Location	Rear Mounted
Depth	30 1/4 Inches	Door Type	Solid
Height	38 3/4 Inches	Exterior Finish	Black
Power Cord Length	108 Inches	Features	Casters Removable Magnetic Door Gaskets
Interior Width	19 1/2 Inches	Horsepower	1/4 HP
Interior Depth	18 1/8 Inches	Number of Doors	1 Doors
Nominal Depth	Standard	Number of Kegs	1 Keg
Faucet Height	10 1/4 Inches	Number of Taps	2 Taps
Interior Height	28 5/8 Inches	Plug Type	NEMA 5-15P
Tap Tower Height	16 Inches	Refrigerant Type	R-290
Tap Tower Diameter	3 Inches	Starting Amps	5.8 Amps
Amps	1.9 Amps	Starting Wattage	648 Watts
Phase	1 Phase	Style	1/2 Barrel
Voltage	115 Volts	Top Capacity	176 lb.
Wattage	216 Watts	Type	Kegerators / Beer Dispensers
Casters	With Casters		

(401)-639-3271

[www.northamericanrefrigeration.com](http://www.northamericanrefrigeration.com)

© 2016 North American Restaurant Equipment

