



# 1 DOOR REFRIGERATED PIZZA PREP TABLE

Model # PPT44

## FEATURES

- Top rail accomodates (5) 1/3" size, 6" deep food pans
- Cutting board built-in for convenient prep space
- Maintains temperatures between 33 and 40 degrees Fahrenheit
- Stainless steel exterior and interior; foamed-in-place polyurethane insulation
- R290 refrigerant; 115V; 1/2hp; 1.88Amps





## PRODUCT SPECIFICATIONS

# 1 DOOR REFRIGERATED PIZZA PREP TABLE

Model # PPT44

### PLAN VIEW

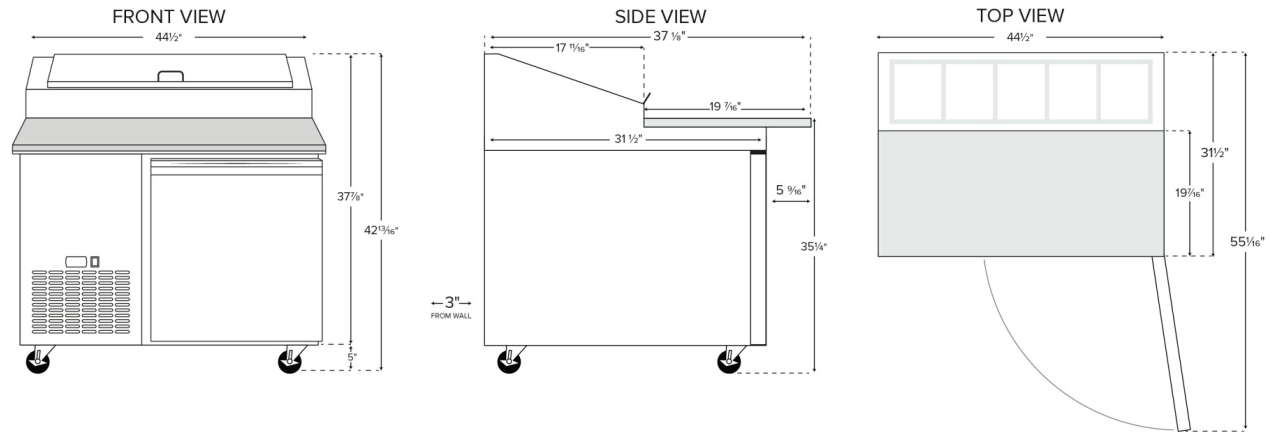

### TECHNICAL DATA

Height	42 13/16 Inches	BTU (LBP)	786
Power Cord Length	98 Inches	Capacity	7.6 cu. ft.
Cutting Board Width	44 1/2 Inches	Compressor Style	Side / Rear Breathing
Interior Width	22 1/4 Inches	Door Style	Swing
Nominal Width	44 Inches	Door Type	Solid
Packaging Width	49.75	Features	Automatic Electric Defrost Digital Temperature Controller
Shelf Width	21 1/2 Inches	Horsepower	1/3 HP
Cutting Board Depth	19 7/16 Inches	Individual Shelf Capacity	90 lb.
Depth (with cutting board)	37 1/8 Inches	Insulation Material	Polyurethane Foam
Interior Depth	26 3/16 Inches	Material	Stainless Steel
Packaging Depth	36.625	Maximum Ambient Temperature	90 Degrees F
Shelf Depth	24 3/8 Inches	Net Weight	287 lb.
Cutting Board Height	3/4 Inches	Number of Doors	1 Doors
Height with Lid Open	56 3/4 Inches	Number of Shelves	1 Shelf
Interior Height	22 7/8 Inches	Plug Type	NEMA 5-15P
Packaging Height	45.875	Refrigerant Type	R-290
Work Surface Height	35 1/4 Inches	Refrigeration Type	Air Cooled
Amps	1.88 Amps	Shelf Material	Epoxy-Coated Steel
Hertz	60 Hertz	Temperature Range	33 - 40 Degrees F
Voltage	115 Volts		
1/3 Size Pan Capacity	5 Pans		
Access Type	Doors		