



# GLASS DOOR MERCHANDISER

Model # PGR2-FG



## Features

- Eco-friendly R290 hydrocarbon refrigerant
- Self-closing, glass swing doors
- 8 epoxy-coated steel shelves hold up to 90 lb. each
- Bright LED lighting
- Maintains temperatures between 33-40 degrees F
- Easy-to-use digital temperature controls
- Foamed-in-place polyurethane insulation
- Black coated steel exterior
- Painted aluminum interior
- Stainless steel floor
- Auto-defrost for easy maintenance

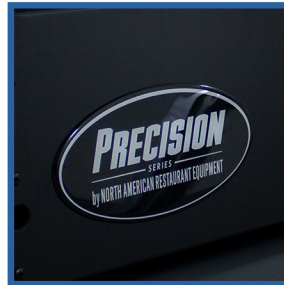

(401)-639-3271

[www.northamericanrefrigeration.com](http://www.northamericanrefrigeration.com)

© 2016 North American Restaurant Equipment





Product Specifications  
Model # PGR2-FG

# GLASS DOOR MERCHANDISER

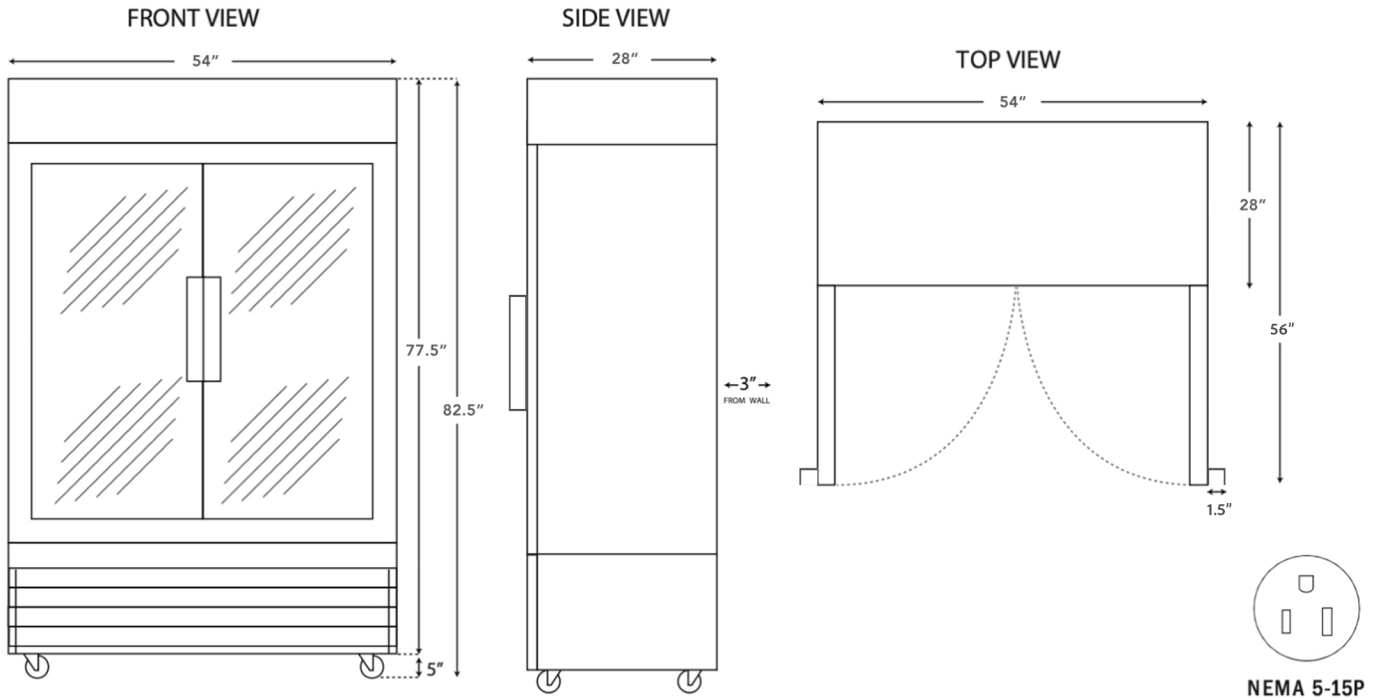

## Dimensions

|            |             |
|------------|-------------|
| Width      | 54 in       |
| Height     | 82.5 in     |
| Depth      | 28 in       |
| Shelf Size | 24in x 23in |
| Weight     | 375 lb      |

## Cooling

|                          |           |
|--------------------------|-----------|
| Temperature Range        | 33F-40F   |
| Refrigerant              | R290      |
| Max. Ambient Temperature | 90        |
| Defrosting               | Automatic |
| Temperature Controller   | Digital   |

## Construction

|                     |                              |
|---------------------|------------------------------|
| Exterior Material   | Black Coated Steel           |
| Interior Material   | Painted Aluminum             |
| Door Type           | Glass Swing                  |
| Insulation Material | Foamed in Place Polyurethane |
| Shelf Material      | Plastic-Coated Steel         |
| Shelf Load Capacity | 90 lb.                       |

## Electrical

|                        |             |
|------------------------|-------------|
| Voltage                | 115         |
| Amps                   | 4.5         |
| Hz                     | 60          |
| Phase                  | 1           |
| Plug Type              | NEMA 5-15 P |
| Electrical Cord Length | 96"         |

(401)-639-3271

[www.northamericanrefrigeration.com](http://www.northamericanrefrigeration.com)

© 2016 North American Restaurant Equipment

