



REACH-IN GLASS SWING DOOR STAINLESS STEEL FREEZER

Model # PGF2-SS

FEATURES

- Stainless steel interior and exterior retains attractive finish longer
- Rounded corner design inside of the cabinet makes it easy to clean the inside storage room
- Standard door features: Self-closing, heavy-duty pull handle, Triple pane thermal insulated glass, Aluminum frames
- LED Lighting
- R290 Refrigeration system holds -8°F to 0°F (-22°C to -18°C) for the best in food preservation
- Electronic control system: Adjustable temperature set point and defrost frequency. Error codes to diagnose service issues
- Shelf: Adjustable, heavy duty PVC coated shelves
- Standard heavy-duty casters make it easy to move and clean underneath
- No stoop lower shelf
- Storage on top of cabinet
- Easily accessible condenser coil for cleaning and easy service access
- Simple installation with no plumbing required





PRODUCT SPECIFICATIONS

REACH-IN GLASS SWING DOOR STAINLESS STEEL FREEZER

Model # PGF2-SS

PLAN VIEW

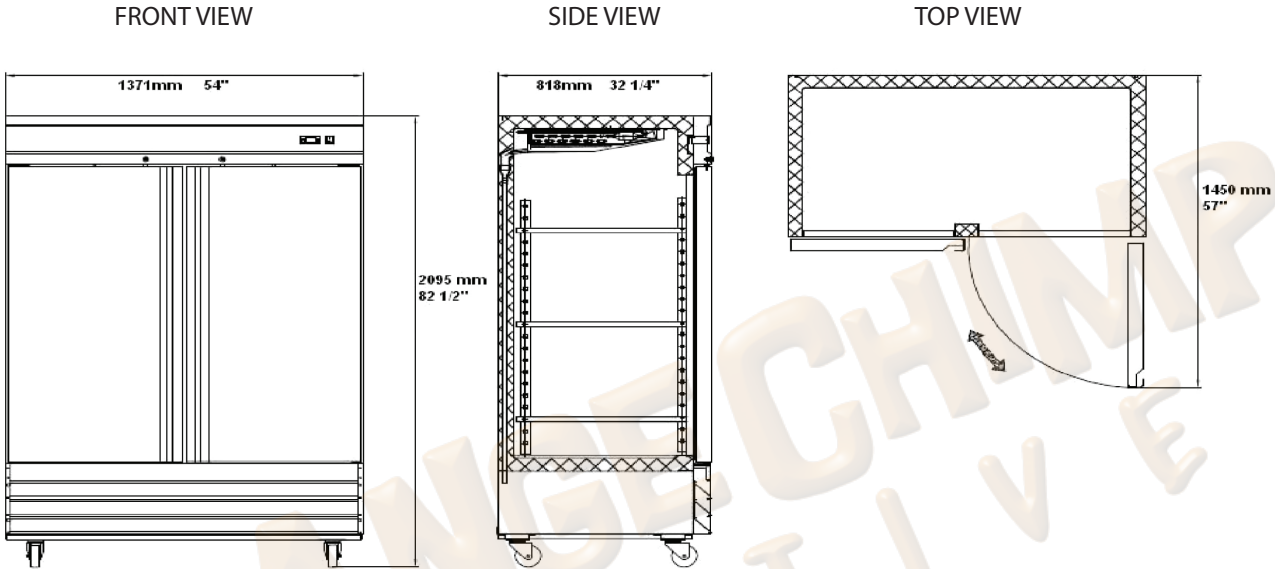

TECHNICAL DATA

MODEL	DOORS	SHELVES	CABINET DIMENSIONS (INCHES)			CAP CU. FT. LITER	HP	VOLTAGE	AMPS	NEMA CONFIGURATION
			LENGTH	DEPTH	HEIGHT					
PGF2-SS	2	6	54"	32.25"	82.5"	47	1.25	115/60/1 230-240/50/1	13.44	5-20P

