

# GLASS DOOR MERCHANDISER FREEZER

Model #P2GDF

## Features

- \* Stainless steel interior and exterior retains attractive finish longer
- \* Rounded corner design inside of the cabinet makes it easy to clean the inside storage room
- \* Standard door features: Self-closing, heavy-duty pull handle, triple pane thermal insulated glass, aluminum frames
- \* LED lighting
- \* R290 refrigeration -8°F to 0°F (-22°C to -18°C)
- \* Electronic control system: Adjustable temperature set point and defrost frequency; error codes to diagnose service issues
- \* Shelf: Adjustable, heavy-duty PVC-coated shelves
- \* Standard heavy-duty casters make it easy to move and clean underneath
- \* No-stoop lower shelf
- \* Storage on top of cabinet
- \* Easily accessible condenser coil for cleaning and easy service access
- \* Simple installation with no plumbing required

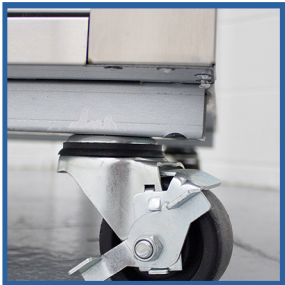

(401)-639-3271

[www.northamericanrefrigeration.com](http://www.northamericanrefrigeration.com)

© 2016 North American Restaurant Equipment





Product Specifications  
Model #P2GDF

# GLASS DOOR MERCHANDISER FREEZER

## PLAN VIEW

FRONT VIEW

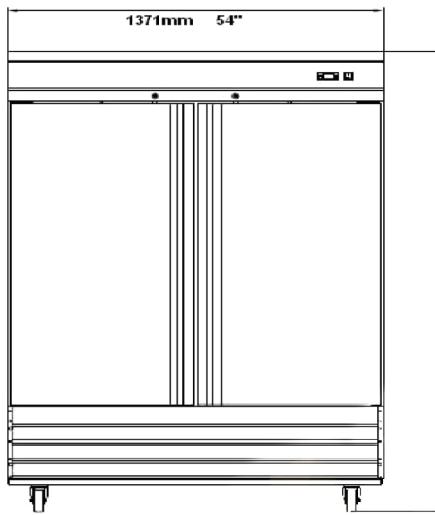

SIDE VIEW

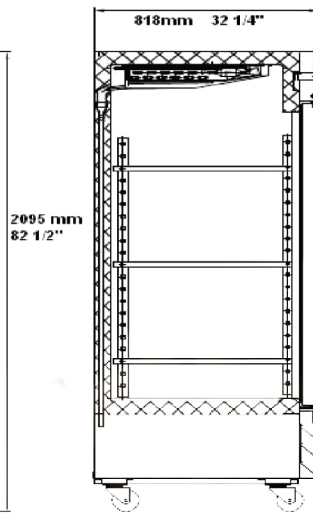

TOP VIEW

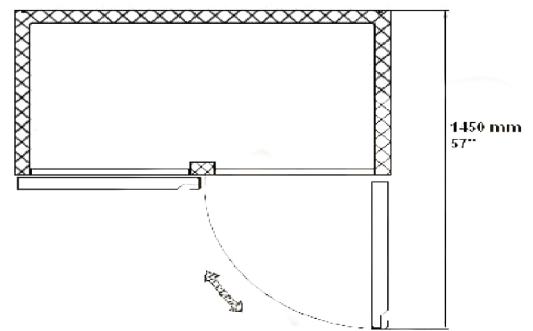

## TECHNICAL DATA

MODEL	DOORS	SHELVES	CABINET DIMENSIONS (INCHES)			CAP CU. FT. LITER	HP	VOLTAGE	AMPS	NEMA CONFIGURATION
			LENGTH	DEPTH	HEIGHT					
P2GDF	2	6	54"	32.25"	82.5"	47	1.25	115/60/1 230-240/50/1	13.44	5-20P

(401)-639-3271

[www.northamericanrefrigeration.com](http://www.northamericanrefrigeration.com)

© 2016 North American Restaurant Equipment



Intertek



Intertek