

HD CHROME 60" COUNTER GRIDDLE

Models: HDTG-60-CHROME

The HD Counter Griddles are extra heavy-duty and feature a 1" griddle plate for quick pre-heat, even heat distribution and fast recovery. Thermostatically controls provide precise operator controlled temperatures from 200° - 450°F (93°- 232° C). Each control features an adjustable air shutter to control air and optimize combustion. Additional specifications include removable stainless steel front panel for easy access to components, stainless steel side panels, stainless splash guard, full-width, front mounted grease trough, removable large capacity drip pan for ease of clean-up and adjustable 4" heavy-duty steel legs.

Featuring:

- Thermostatic Controls
- Each Burner has Adjustable Heat Control, On/Off Control Valves and Adjustable Air Shutter for Perfect Combustion
- Available in 2, 3, 4, or 5 Burner Models
- 1" Griddle Plate
- Stainless Steel Front, Sides and Splash Guard
- Easily Removable from Panel
- Convertible From NG to LP – Conversion Kit Included
- Large Capacity, Removable Drip Pan
- Full-Width, Front Mounted Grease Trough



HD CHROME COUNTER GRIDDLES

Models: HDTG-24-CHROME, HDTG-36-CHROME, HDTG-48-CHROME, HDTG-60-CHROME

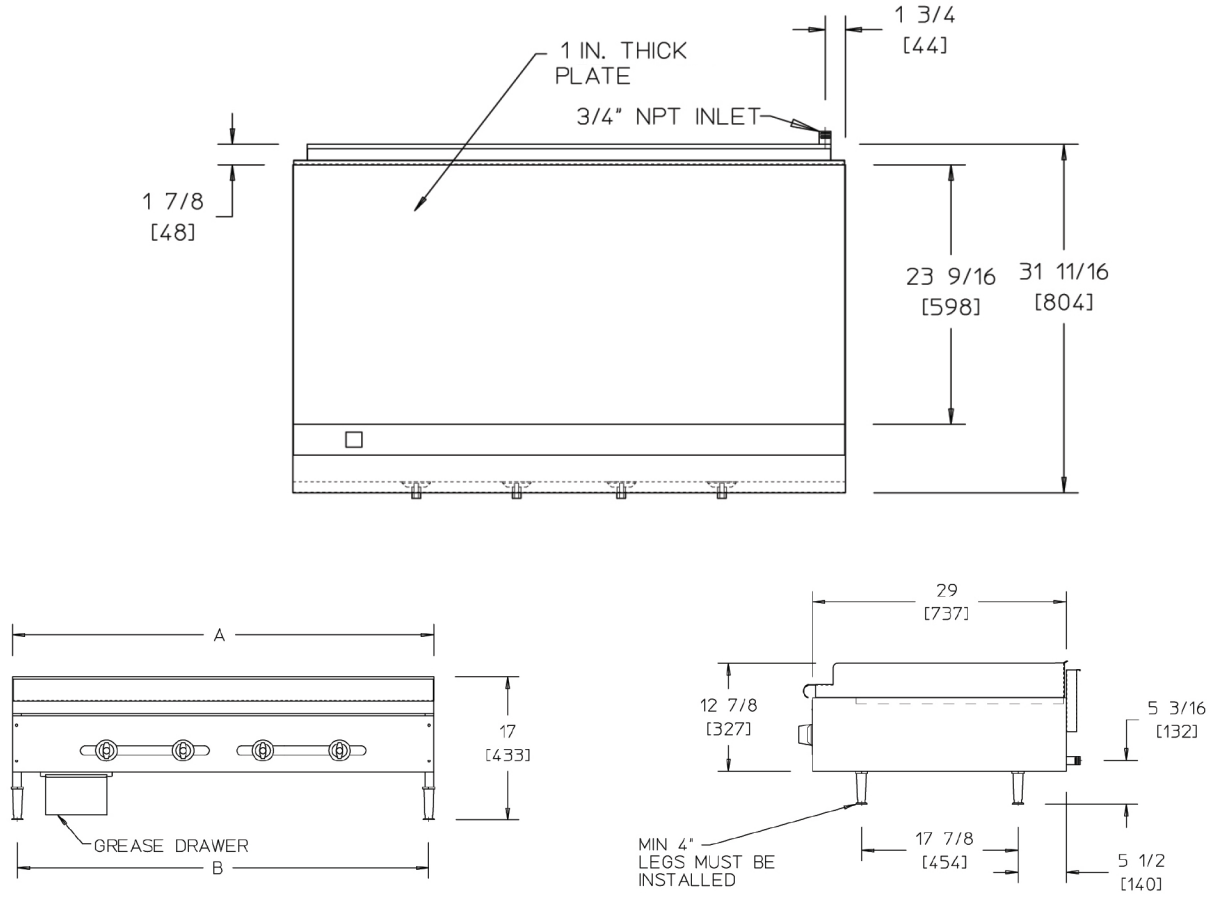

HD COUNTER GRIDDLE - PRODUCT SPECIFICATIONS

Model	# of Controls	Width (A) (MM)	Width (B) (MM)	Depth (MM)	Height (MM) Includes 4" Legs	BTU Rating		Approx. Ship Weight lbs. (kg)	Approx. Install Weight lbs. (kg)
						Natural GAS 5" W.C.	LP GAS 10" W.C.		
HDTG-24	2	24-1/8" (613)	23" (584)	31-11/16" (804)	17" (433)	60,000	60,000	249 (113)	199 (90)
HDTG-36	3	36-1/8" (917)	35" (889)	31-11/16" (804)	17" (433)	90,000	80,000	397 (180)	287 (130)
HDTG-48	4	48-1/8" (1222)	47" (1194)	31-11/16" (804)	17" (433)	120,000	120,000	507 (230)	393 (178)
HDTG-60	5	60-1/8" (1527)	59" (1499)	31-11/16" (804)	17" (433)	150,000	150,000	640 (290)	530 (240)

Specifications subject to change without notice

