

PLATE CHILLER / GLASS FROSTER

Model #GF24

Features

- Eco-friendly R290 hydrocarbon refrigerant
- 4 epoxy-coated steel shelves for glasses or plates
- Sliding stainless steel door for easy access
- Maintains temperatures between -5 and -2°F
- Easy-to-use, digital temperature controls
- Foamed-in-place polyurethane insulation
- Black coated steel exterior
- Painted aluminum interior
- Auto defrost for easy maintenance
- 115V; 1/5HP
- Warranty is 5 year compressor 3 year parts
- 1 year labor



(401)-639-3271

www.northamericanrefrigeration.com

© 2016 North American Restaurant Equipment





Product Specifications
Model #GF24

PLATE CHILLER / GLASS FROSTER

PLAN VIEW

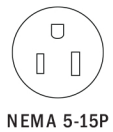
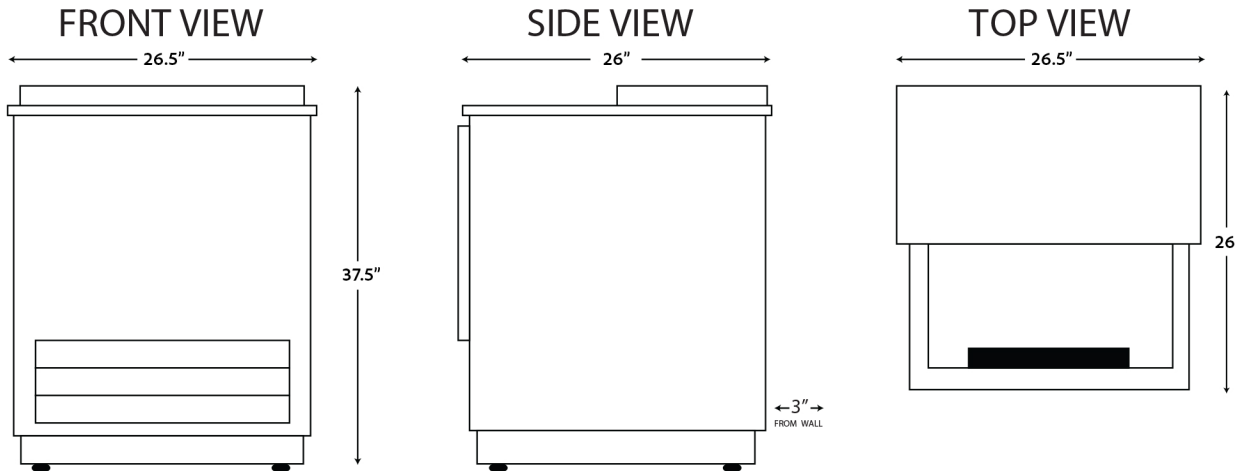

TECHNICAL DATA

Dimensions

Exterior Dimensions	26.5"W x 26"D x 37.5"H
Net Volume	4.1 cu. ft.
Net Weight	125 lb.
Gross Weight	158 lb.
Packaging Dimensions	32"W x 33"D x 42"H

Cooling

Temperature Range	-5 - 2°F
Refrigerant	R290
Max. Ambient Temperature	90°F
Defrosting	Automatic
Temperature Controller	Digital
Horsepower	1/5

Construction

Exterior Material	Black Plastic Coated Steel
Interior Material	Painted Aluminum
Insulation Material	Foamed-In-Place polyurethane
Shelves	(4) 9¾" x 22"
Shelf Material	Epoxy Coated Steel
Shelf Load Capacity	40 lb.

Electrical

Voltage	115
Amps	3.3
Hz	60
Phase	1
Plug Type	NEMA 5-15P
Electrical Cord Length	90"

(401)-639-3271

www.northamericanrefrigeration.com

© 2016 North American Restaurant Equipment

