



# TRIPLE GALLON BOWL BEVERAGE DISPENSER WITH STIRRING SYSTEM

Model # CBD-3

## FEATURES

- Stirring system
- Stainless steel base , dip tray, valve, handle, cylinder
- Polycarbonate bowl with lid
- Non-slip feet for stability
- 44.6 °F to 53.6°F temperature range
- Rotating cylinder and paddle keep constantly mixing
- ON/OFF switch for power
- High performance refrigeration
- 6' power cord with NEMA 5-15 plug





## PRODUCT SPECIFICATIONS

# TRIPLE GALLON BOWL BEVERAGE DISPENSER WITH STIRRING SYSTEM

Model # CBD-3

### PLAN VIEW

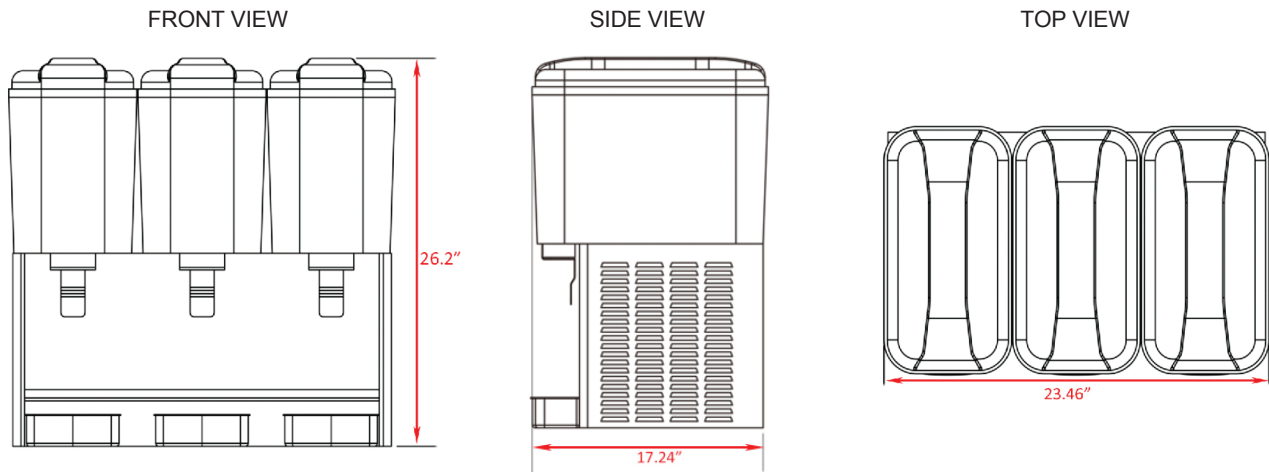

### TECHNICAL DATA

Exterior Dimensions	23.4"W x 17.2"D x 26.2"H	Hertz	60
Packaging Dimensions	25.2"W x 18.9"D x 28"H	Phase	1
Capacity	9.6 Gallons	Amps	3
Capacity per Container	3.2 Gallons	Wattage	320
Number of 12 oz. Servings	102	Plug Type	NEMA 5-15P
Unit Weight	73 lb.	Power Cord Length	72"
Shipping Weight	80 lb.	Temperature Range	44.6 °F to 53.6°F
Voltage	115	Refrigerant	R290