

REACH-IN REFRIGERATORS/FREEZERS

Model Numbers: A1DC, A1DF, A2DC, A2DF

HIGHLIGHTS

- Meets or exceeds NSF, ETL, UL Standard
- Self-Closing Doors
- Magnetic Door Gaskets
- All Stainless Interior and Exterior
- 3 Adjustable Epoxy-Coated Shelves Per Door
- Molded Door Handles and All Stainless Steel Exterior for a Sleek, Easy-to-Clean Design
- Bottom Mount Refrigeration System for Easy maintenance
- Easily Movable on Locking Casters
- Digital Temperature Control for Maintaining and Monitoring Proper Food Temperatures
- Heavy Insulated Cabinet for Lower Energy consumption
- Full-Size Interior Featuring a Huge 23 cubic ft. Capacity on Models A1DC and A1DF and 49 cubic ft. Interior on Models A2DC and A2DF
- Automatic Electronic Defrost on All Models
- 5 Year Compressor Warranty, 3 Year Parts Warranty and 1 Year Labor Warranty

A1DC



A2DC



A1DF



A2DF



REACH-IN REFRIGERATORS/FREEZERS

Model Numbers: A1DC, A1DF, A2DC, A2DF

A1DC / A1DF

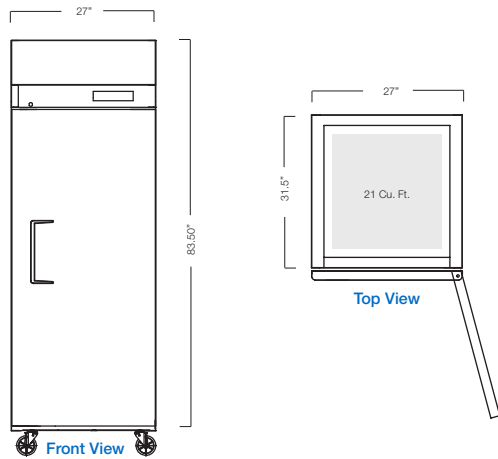

A2DC / A2DF

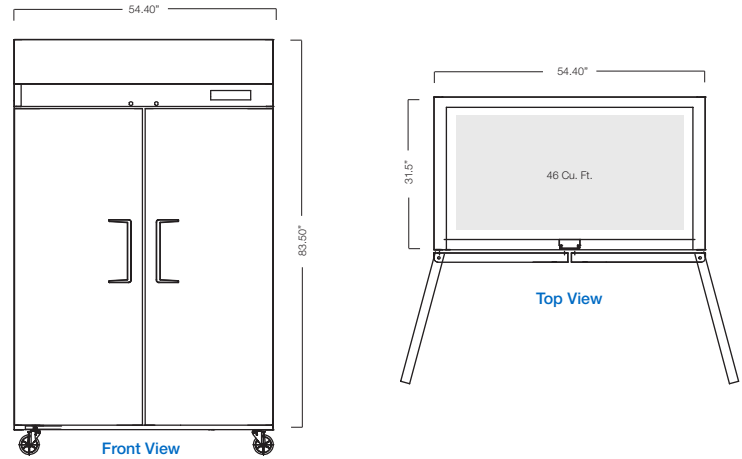

REACH-IN REFRIGERATORS/FREEZERS - PRODUCT SPECIFICATIONS

SKU	A1DC / A1DF	A2DC / A2DF
Dimensions	27"W x 31.5"D x 83.5"H	54.4"W x 31.5"D x 83.5"H
Shipping Dimensions	28.7"W x 33.1"D x 88.6"H	56.1"W x 33.1"D x 85"H
Capacity	21 Cu. Ft.	46 Cu. Ft.
Inner Temperature	33° F - 38° F / -8° F - 0° F	33° F - 38° F / -8° F - 0° F
Doors	1	2
# of Shelves	3	6
Refrigerant	134A / 404A	134A / 404A
Cooling Type	Ventilated	Ventilated
Insulation Type	Polyurethane	Polyurethane
Temperature Control Type	Dixell	Dixell
Amps (A) 115V/60Hz	4	6.5
Watts	300	590
Net Weight	276lbs	430lbs

